



SHTTL- Design

Xander Li, Manny Hur, Joanna Wickersham



Application Area

Cooking



Baking



Clutter Management



Hardware



Software

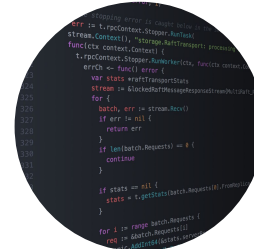

Solution Approach

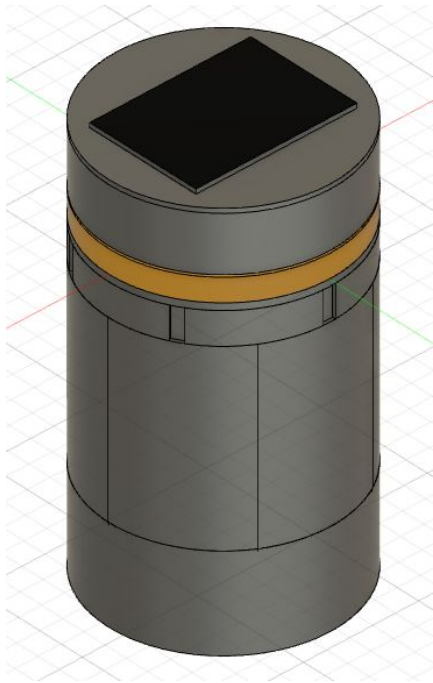

- 6 Spices
- Accurate Dispense
- Usage Tracking
- Starbucks Venti Size!
- APP via Bluetooth

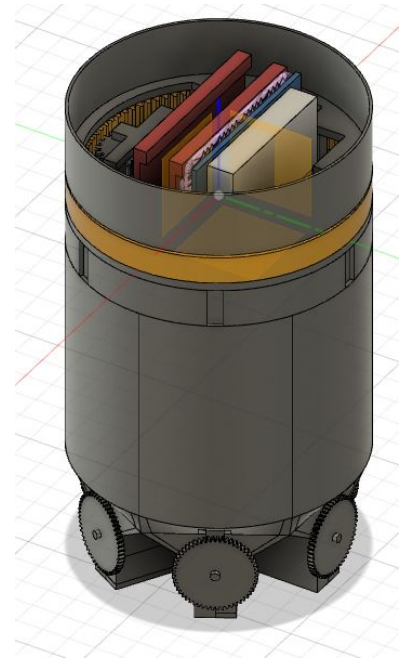

Block Diagram

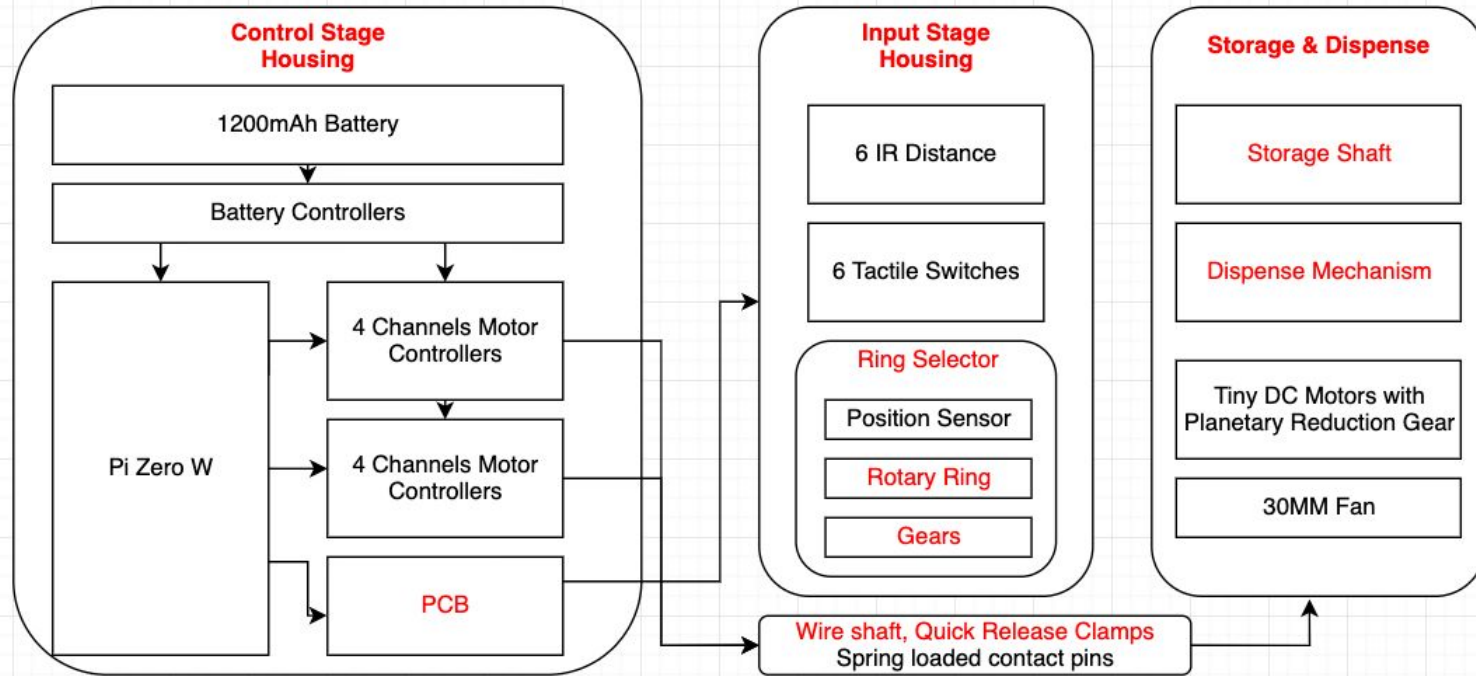

*black labels are off the shelf

Electronics

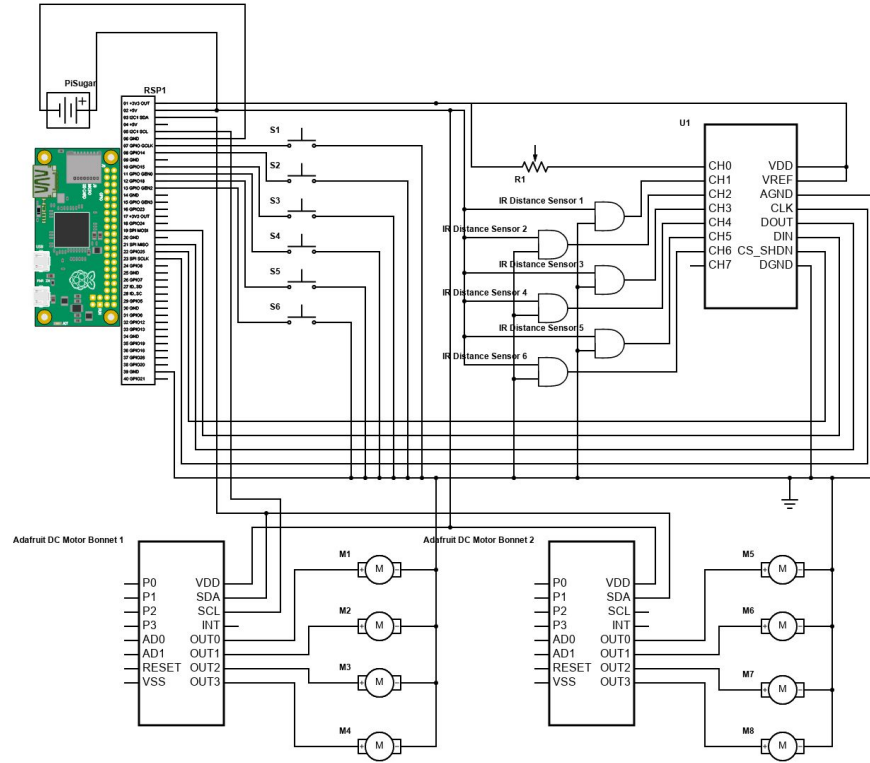

Implementation Plan (Buy)

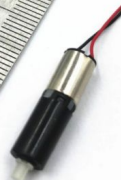
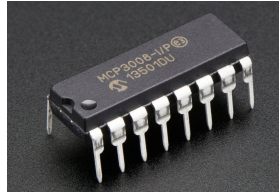
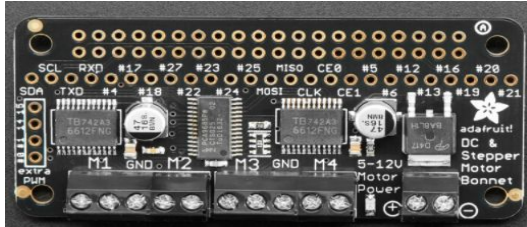

6mm four-stage deceleration

(Make)

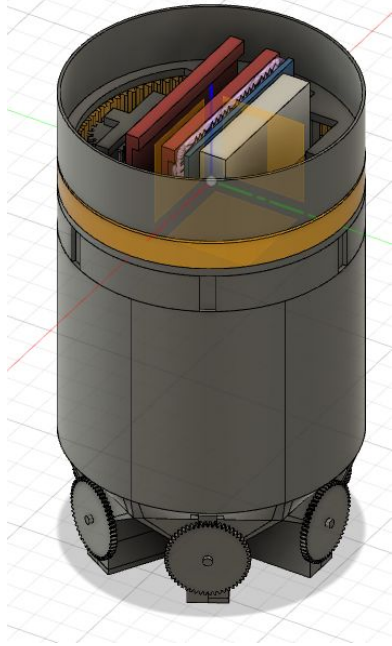

Overall

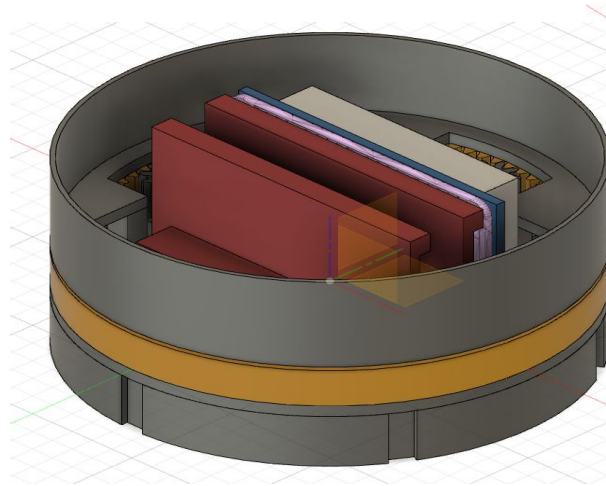

Electronics housing

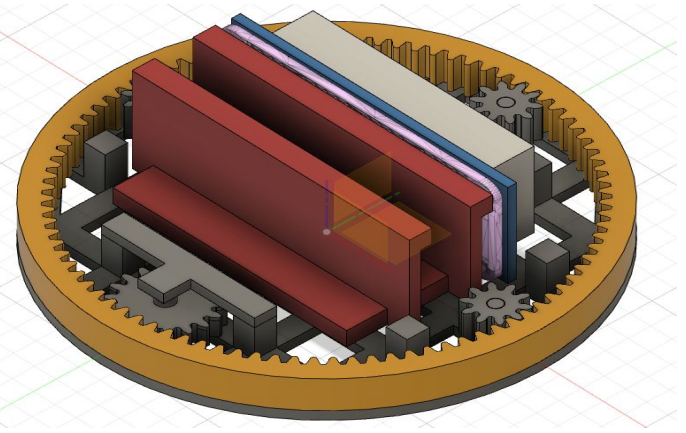

Ring selector

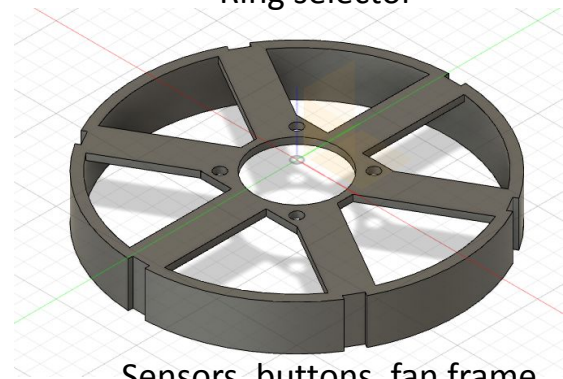

Sensors, buttons, fan frame



Storage & Dispense
6 Spices

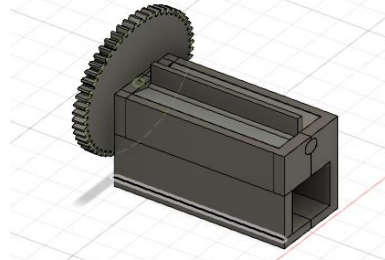
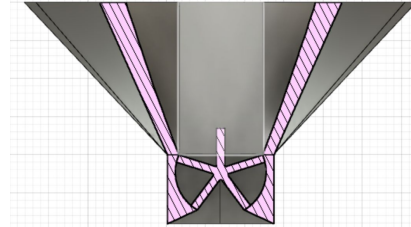
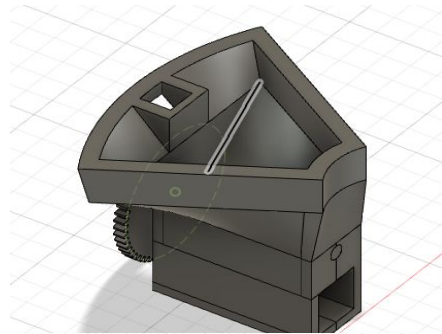
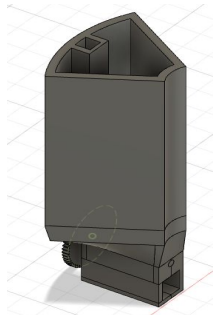

Dispense

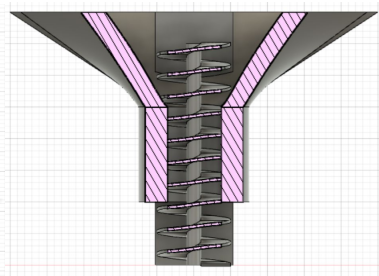
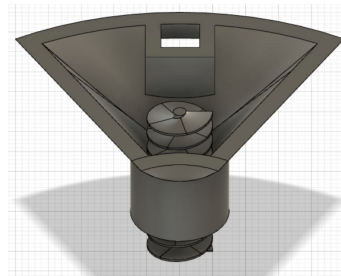

Vertical Auger (Option 2)

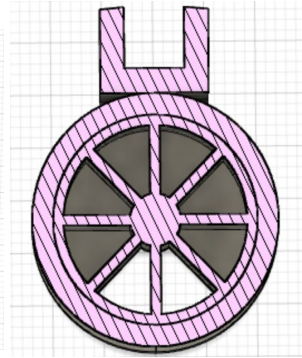
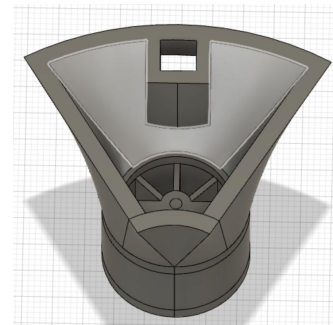

Rotary Cup (Option 3)

Validation & Testing

	Passing Requirements	Test Methods	Risk & Mitigation
Weight (empty)	< 500g	Scale	All wall thickness can be decreased
Charging Speed	< 5hrs (0-100%)	Drain and charge	
Size	4*4*8.75	Measure	Flexible on height
Battery Life	2 days nominal use With 100 dispense/day	Manually dispense until battery die	Very conservative on this estimate
Dispense Accuracy	+/- 10% of target	Scale	Multiple dispense design developing

	Passing Requirements	Test Methods	Risk & Mitigation
Dispense Speed	1 tsp/s	Scale & Timer	Gear ratio can be adjusted
Spray Radius	6" diameter when 6" from target 2" min -12"max	Dispense trials on white piece of paper, measure distance	Nozzle shape is flexible, modular design
Noise level	<60db	Measure with phone app	3D printed parts quality
Jamming Rate	1/ mo	Monitor over month(s) of testing	3D printed parts quality

Unknowns

DC motor controller accuracy: Speed control, Consistency (this affects dispense accuracy)

Battery Management: Disruption during charging, reboots

Idle Power Consumption: All the sensors, Pi idling

Week 1

Week 2

Week 3

Week 4

Week 5

Week 6

Week 7

Week 8

Week 9

Week 10

Week 11

Weekly Meetings, Status Reports

Proposal Presentation

Order Parts

Initial Designs

Electronic Design

Power Analysis

3 Operation Dispense Mechanisms

PCB Design

Initial Testing

Print Initial Dispense Mechanisms

Dispense Integration with Motors

Compatibility

CAD support for upper assembly

Sensor Integration

IOS Bluetooth Testing

Minimal IOS UI

Upper/ Lower Connection Design

Volume Control

UI Integration

Upper/ Lower Connection

Terminal Base

Upper Assembly Integration

Iteration & Testing

final presentation

Legend:

All

Joanna

Xander

Manny

Xander/Manny

Joanna/Manny

Xander/Joanna