

SYSTEM BLOCK DIAGRAM	
TITLE: Rev1 Schematic v34	
Document Number:	REV:
Date: 2/26/2021 8:14 PM	Sheet: 1/12

1

2

3

4

5

6

A

A

B

B

C

C

D

D

E

E

PRE-AMP DIGITAL POTENTIOMETER (QUAD)
ADDR BITS = 00

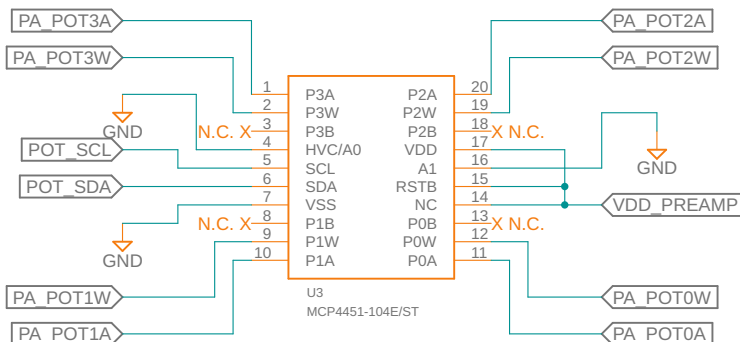

NOTES:
1. Place one 0.1uF capacitor near each IC.

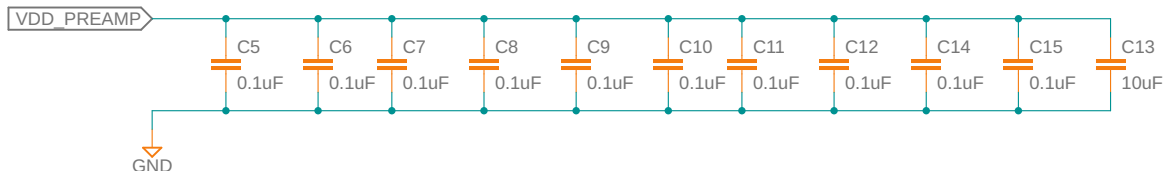

VREF = LOW-IMPEDANCE VIRTUAL GROUND

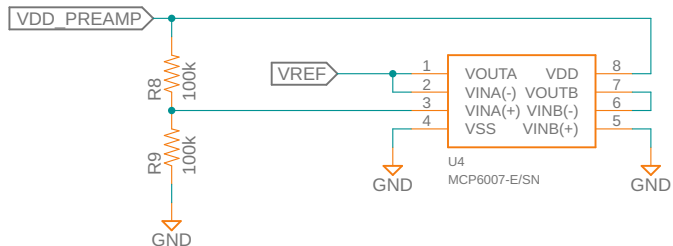

PRE-AMPLIFIER (Digipots and Supplies)

TITLE: Rev1 Schematic v34

Document Number:

REV:

Date: 2/26/2021 8:14 PM

Sheet: 2/12

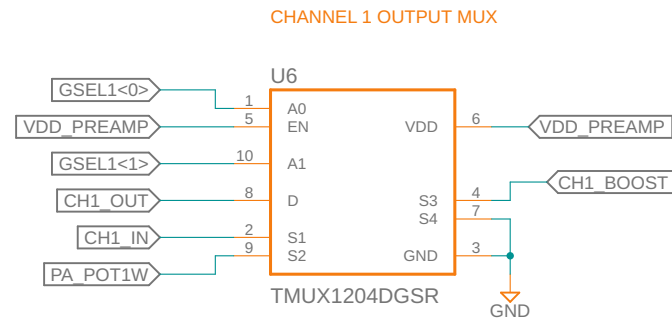
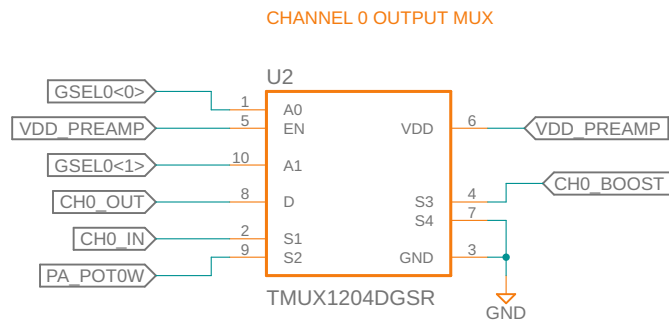
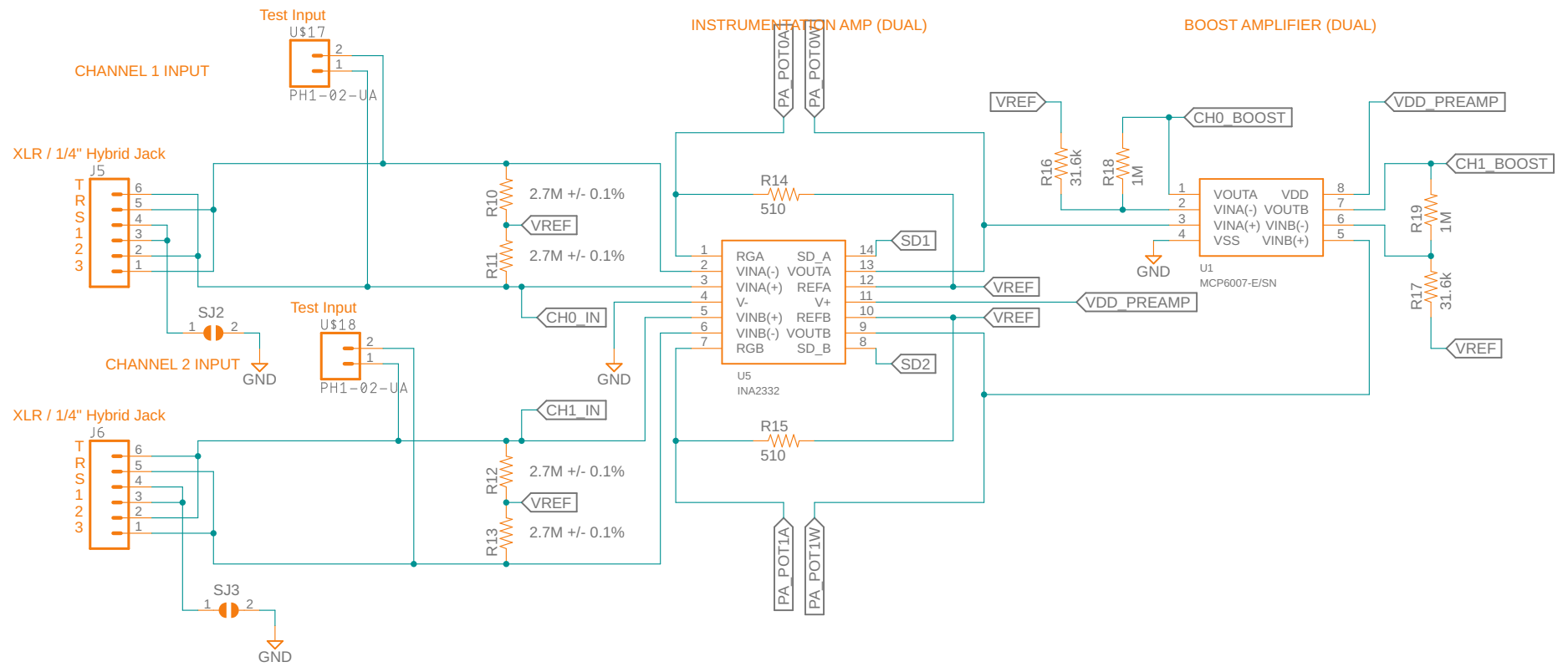

PRE-AMPLIFIER (Channel 0 and 1)

TITLE: Rev1 Schematic v34

Document Number:

REV:

Date: 2/26/2021 8:14 PM

Sheet: 3/12

ANALOG EFFECT BASS/TREBLE POT. FOR CH0-1 (QUAD)
ADDR BITS = 01

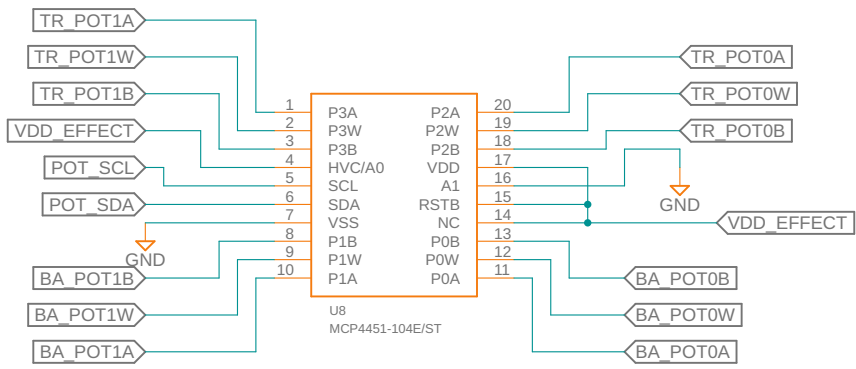

ANALOG EFFECT OVERDRIVE POT. (QUAD)
ADDR BITS = 11

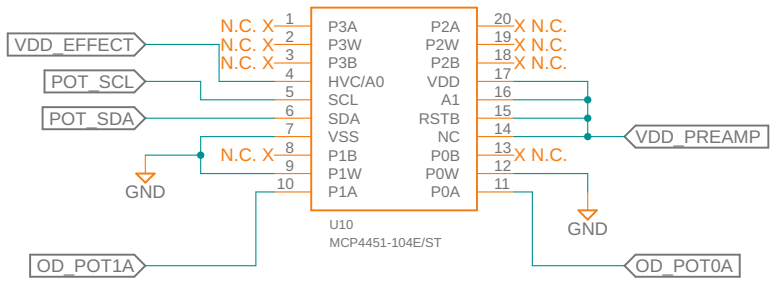

ANALOG EFFECT (Digipots)

TITLE: Rev1 Schematic v34	
Document Number:	REV:
Date: 2/26/2021 8:14 PM	Sheet: 4/12

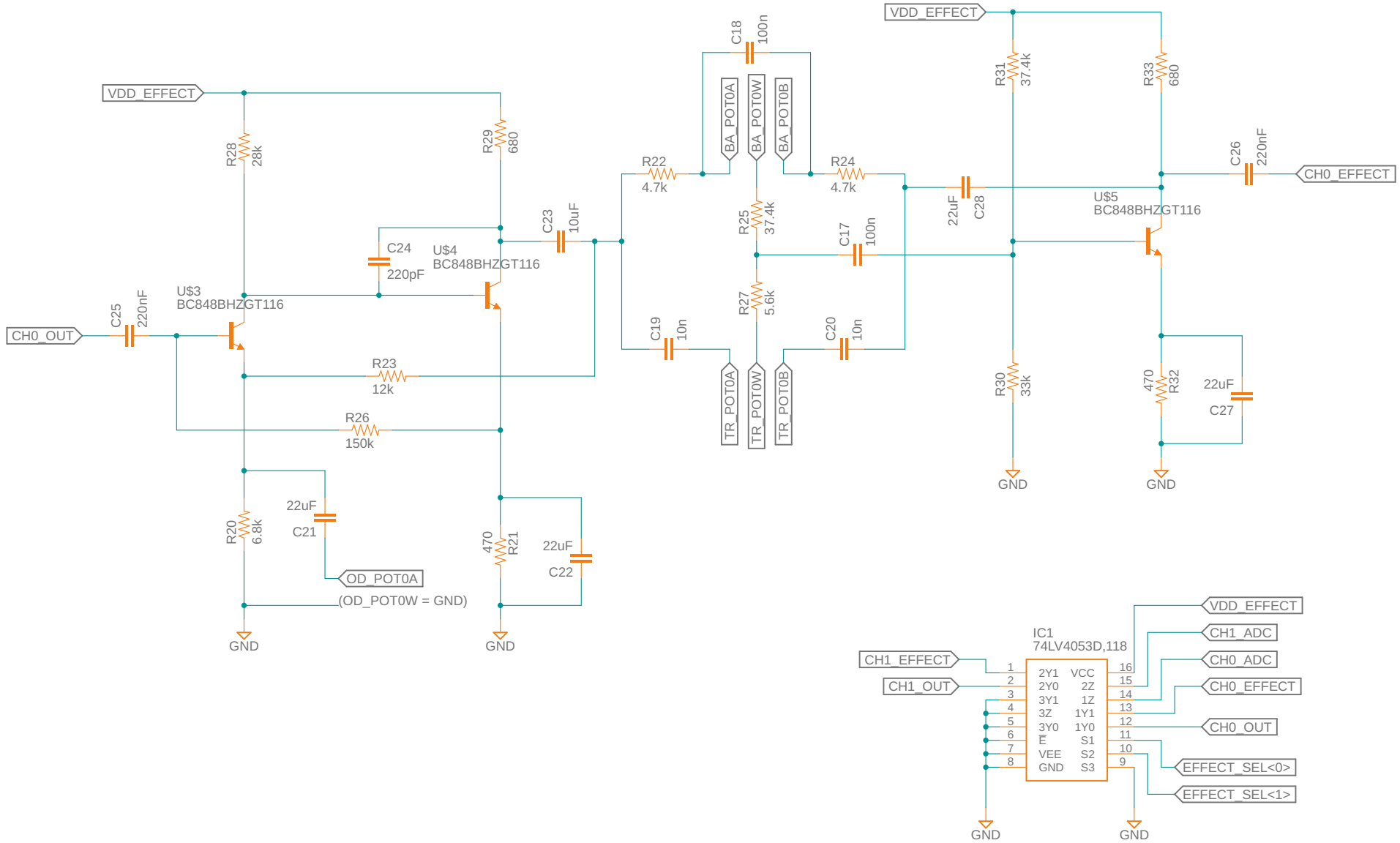

ANALOG EFFECT (Channel 0)

TITLE: Rev1 Schematic v34

Document Number:

REV:

Date: 2/26/2021 8:14 PM

Sheet: 5/12

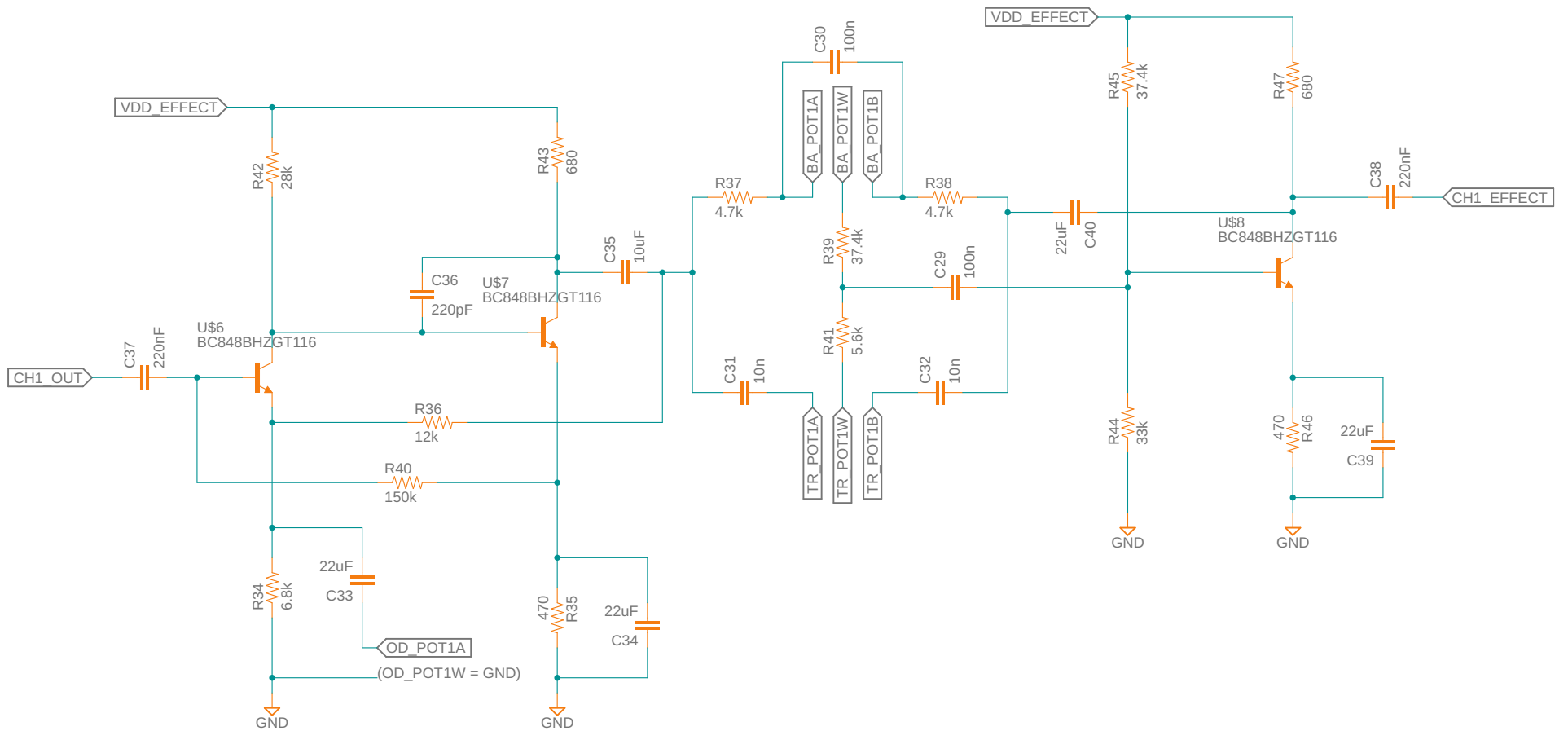

ANALOG EFFECT (Channel 1)

TITLE: Rev1 Schematic v34

Document Number:

REV:

Date: 2/26/2021 8:14 PM

Sheet: 6/12

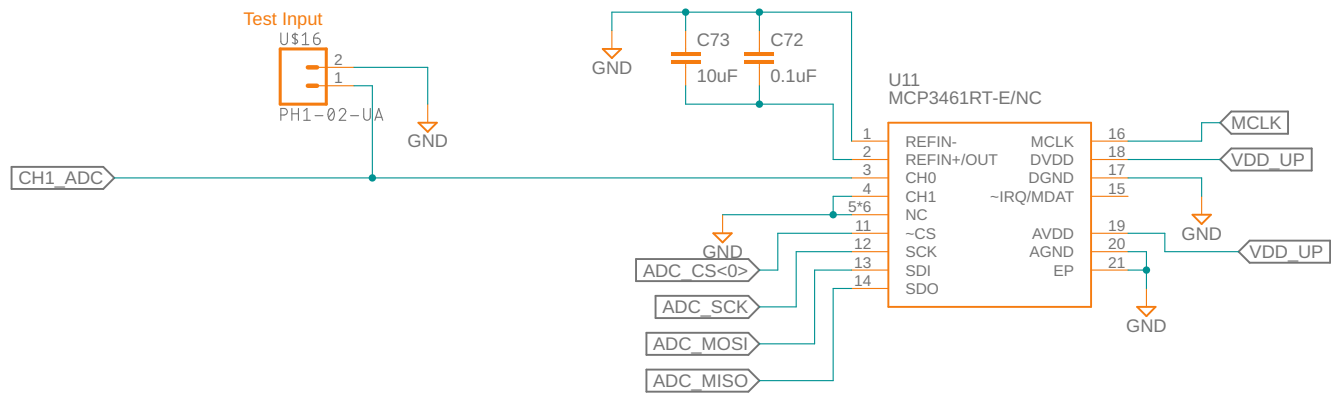
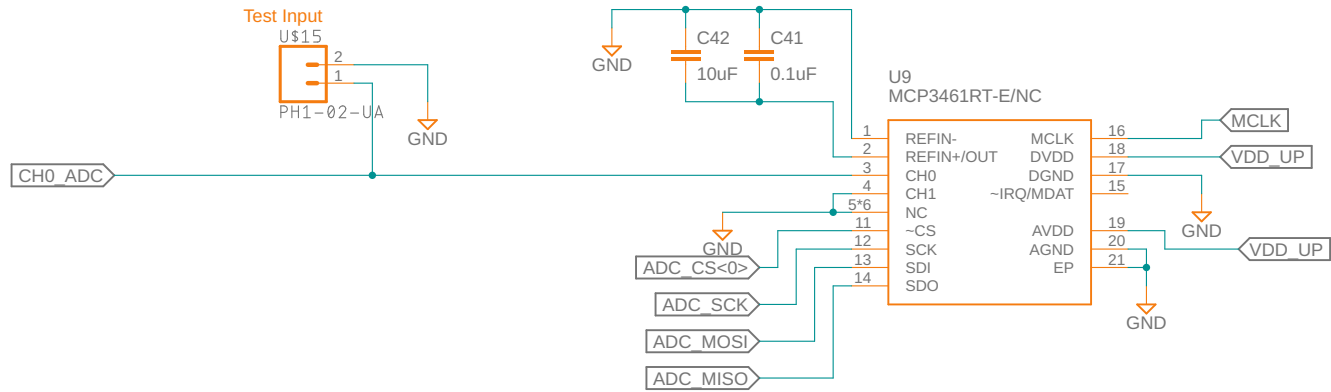

MICROPROCESSOR (External ADCs)

TITLE: Rev1 Schematic v34

Document Number:

REV:

Date: 2/26/2021 8:14 PM

Sheet: 7/12

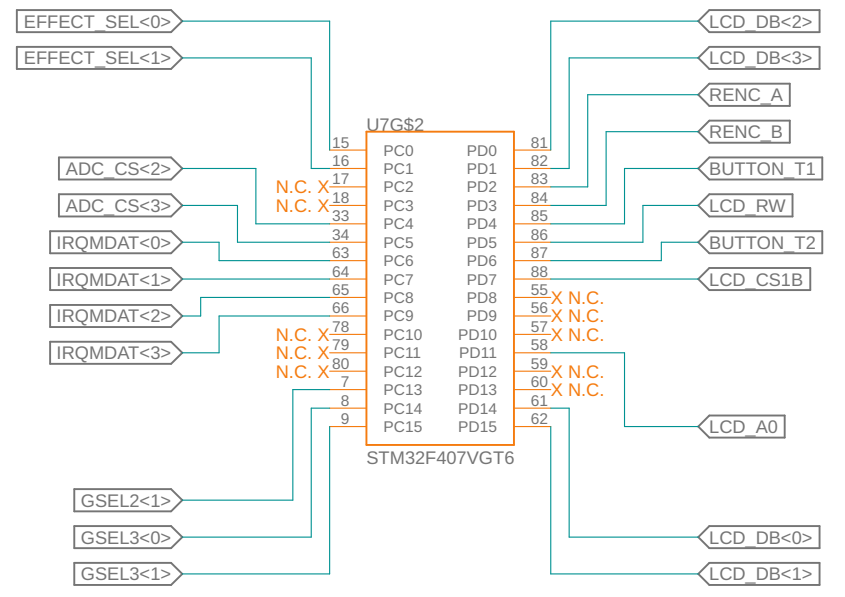
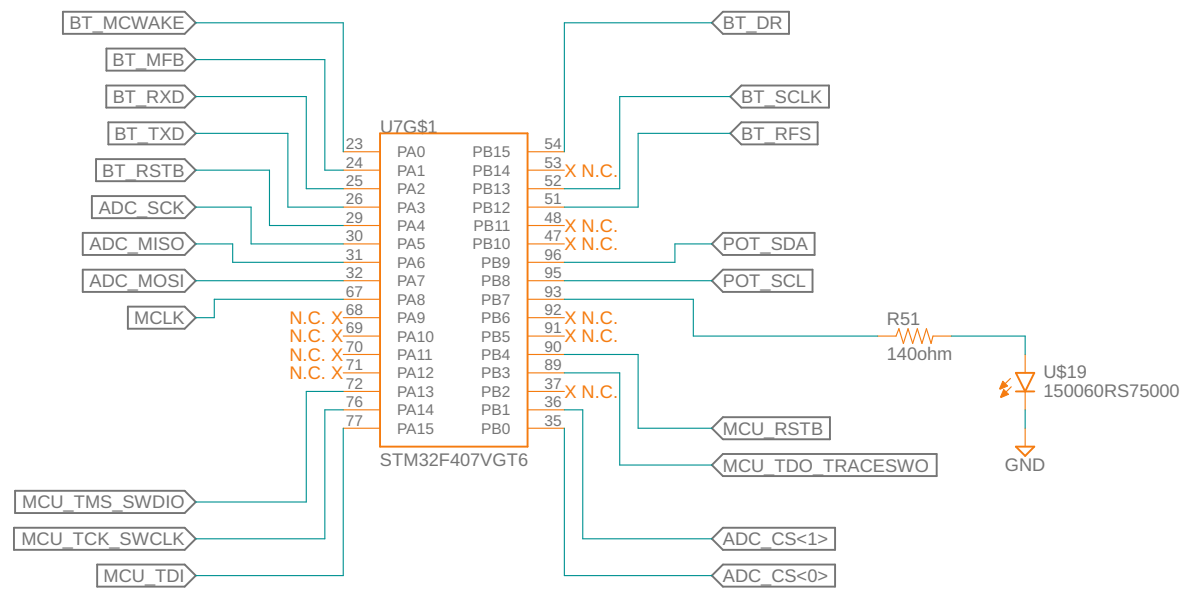

MICROPROCESSOR: (I/O Ports)	
TITLE: Rev1 Schematic v34	
Document Number:	REV:
Date: 2/26/2021 8:14 PM	Sheet: 8/12

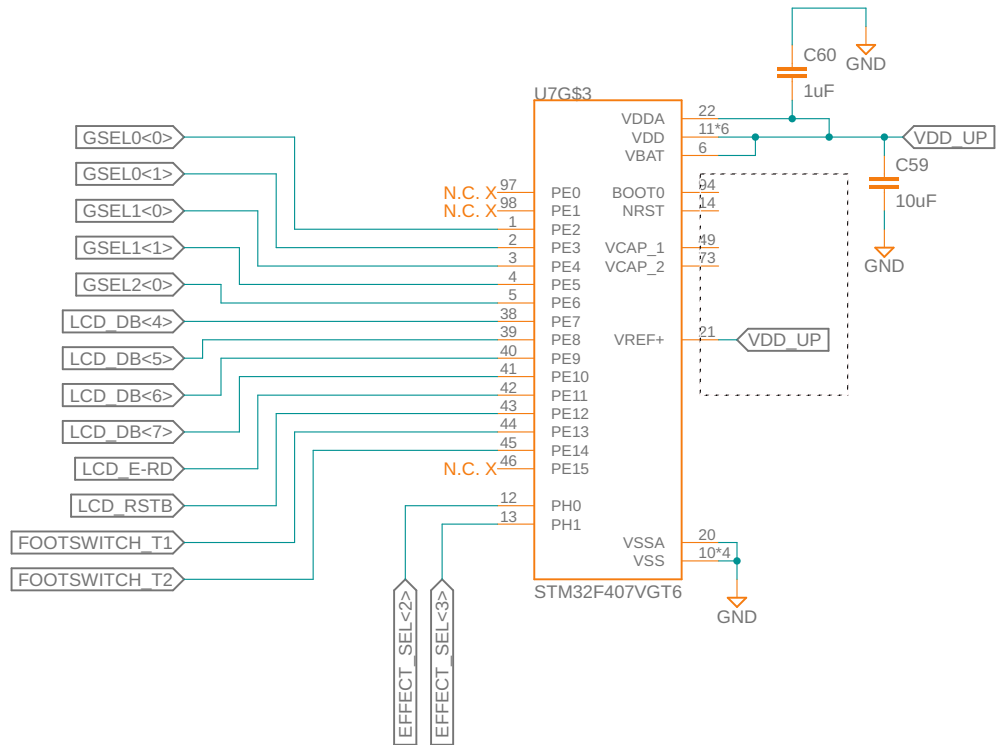
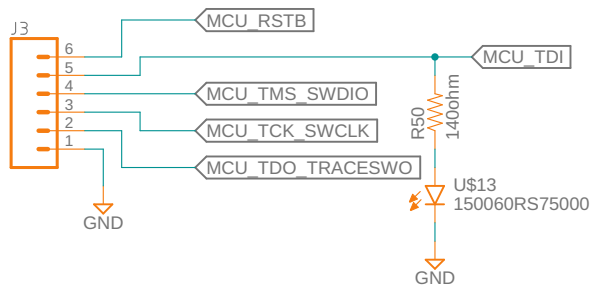

NOTE
Each VDD/VSS pair (15 tot.) and VDDA/VSSA should be decoupled with 0.1uF

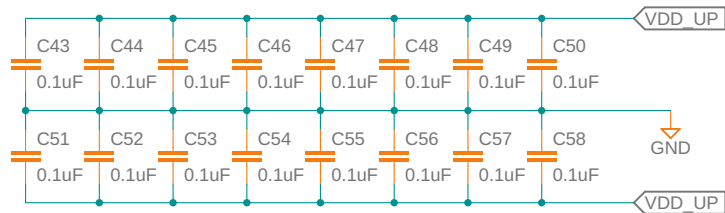

MICROPROCESSOR (Miscellaneous)

TITLE: Rev1 Schematic v34

Document Number:

REV:

Date: 2/26/2021 8:14 PM

Sheet: 9/12

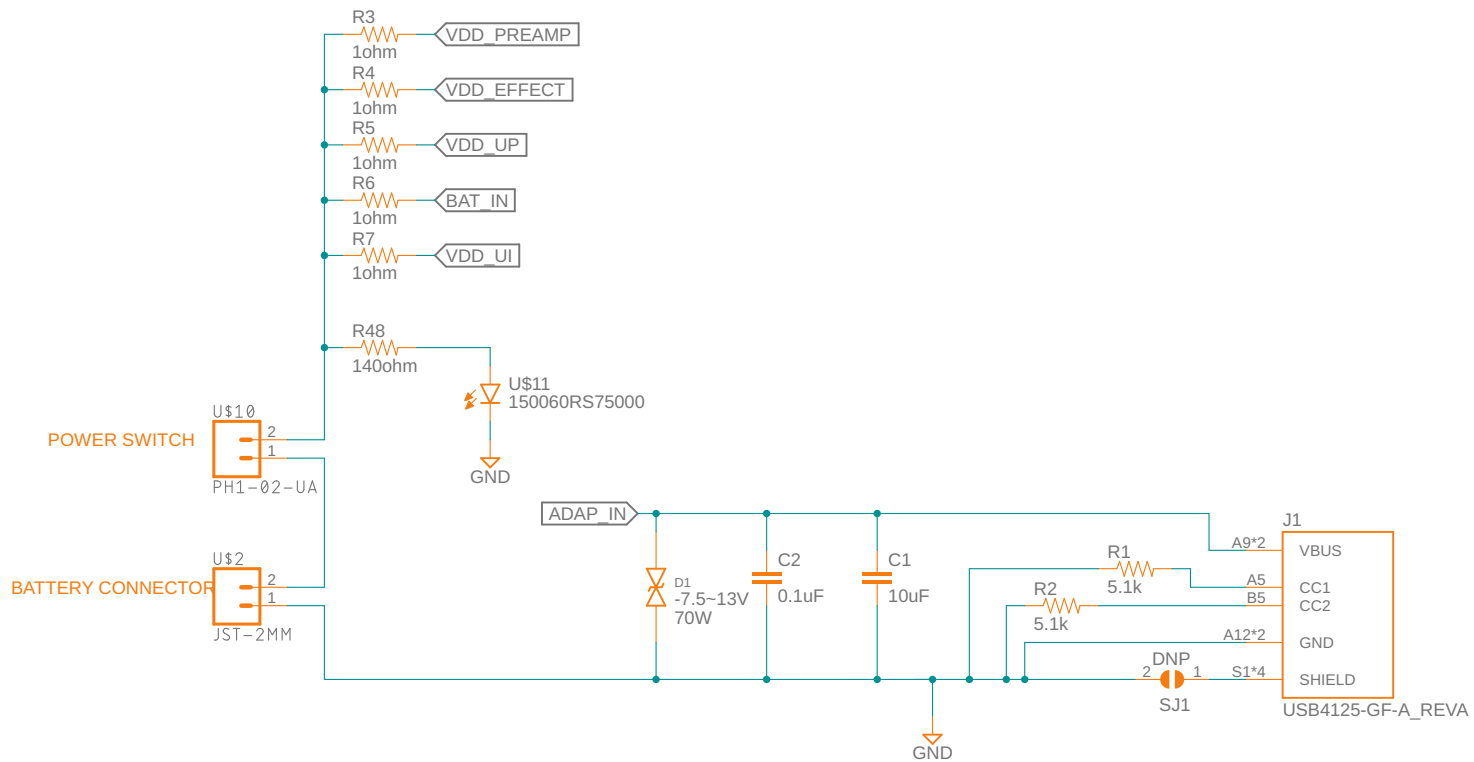

POWER MODULE

TITLE: Rev1 Schematic v34

Document Number:

REV:

Date: 2/26/2021 8:14 PM

Sheet: 10/12

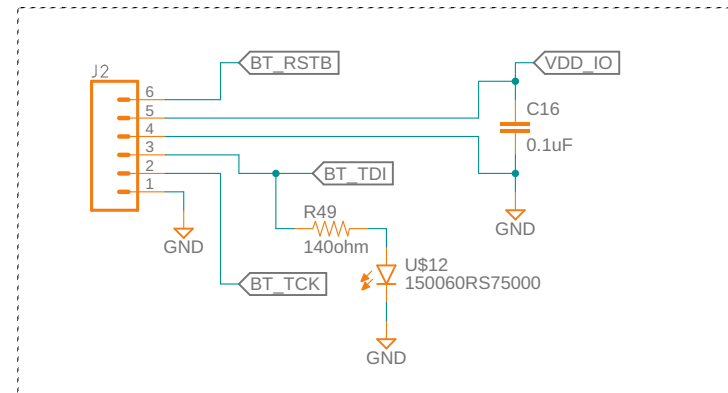
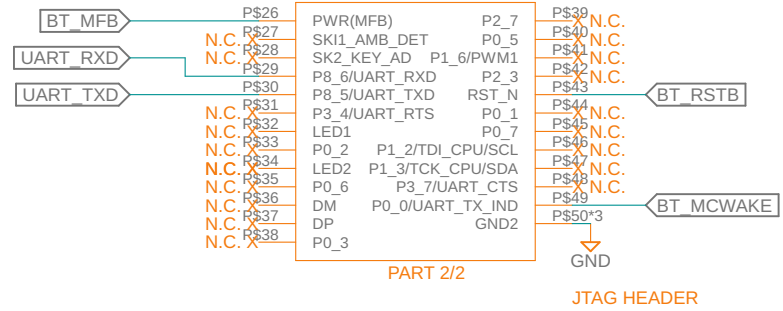
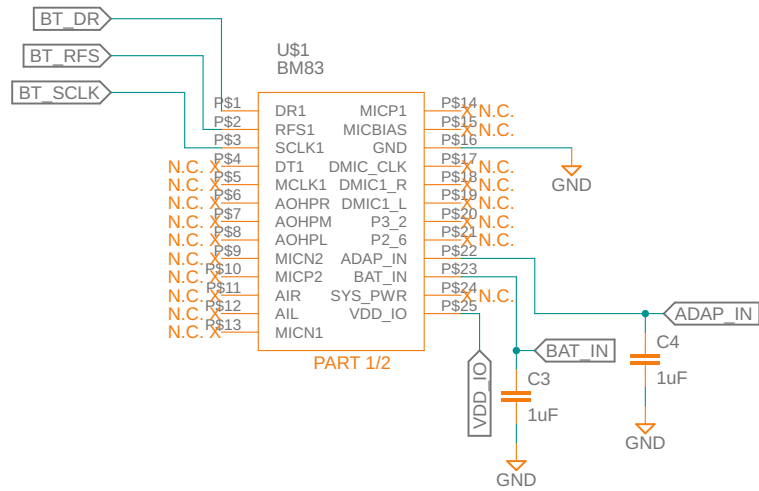

BLUETOOTH MODULE

TITLE: Rev1 Schematic v34

Document Number:

REV:

Date: 2/26/2021 8:14 PM

Sheet: 11/12

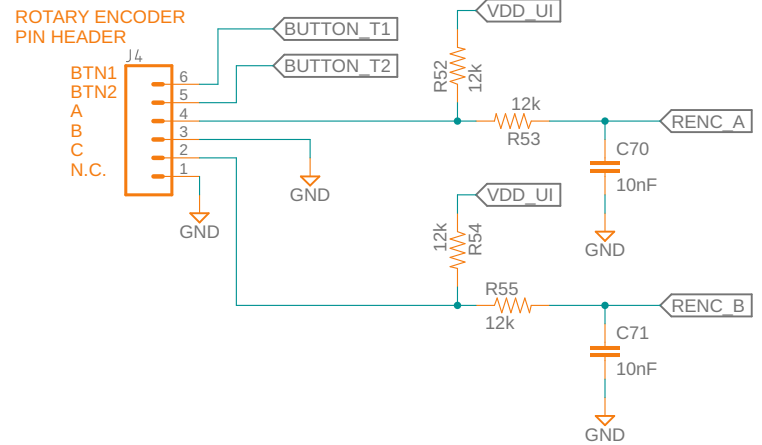
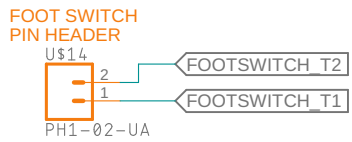
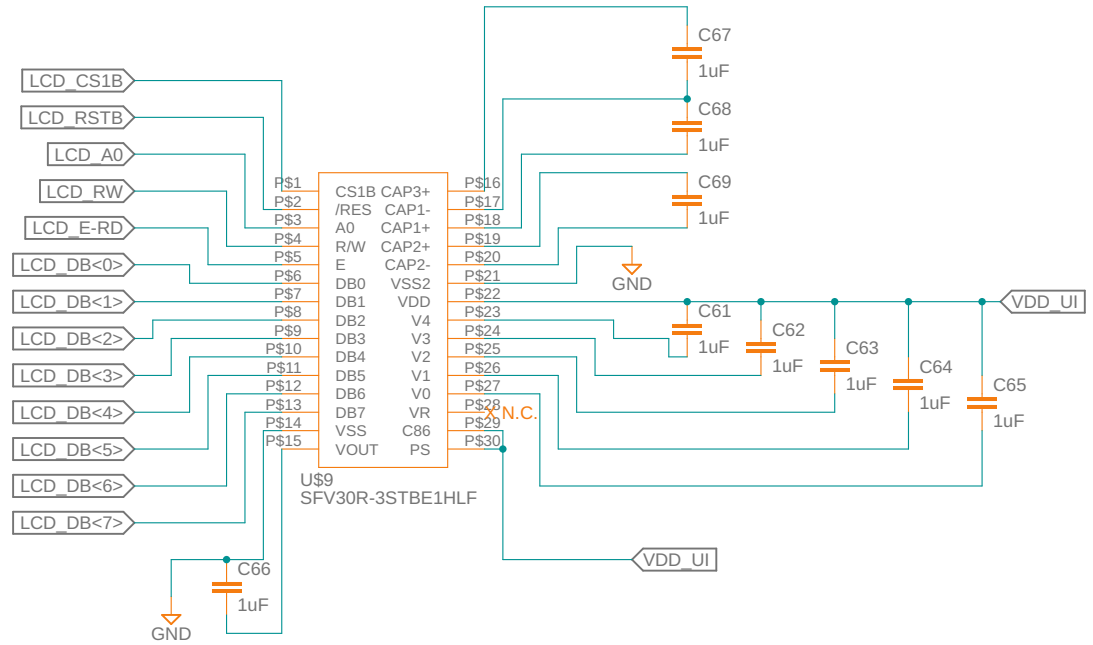

UI MODULE

TITLE: Rev1 Schematic v34

Document Number:

REV:

Date: 2/26/2021 8:14 PM

Sheet: 12/12