

625234<#6-3=#@31k8##=-Xvhw G rfxp hqw HDJ OH surhfw Dp IfdDxud Dp IfdDxudvfk#Vkhhw#12<

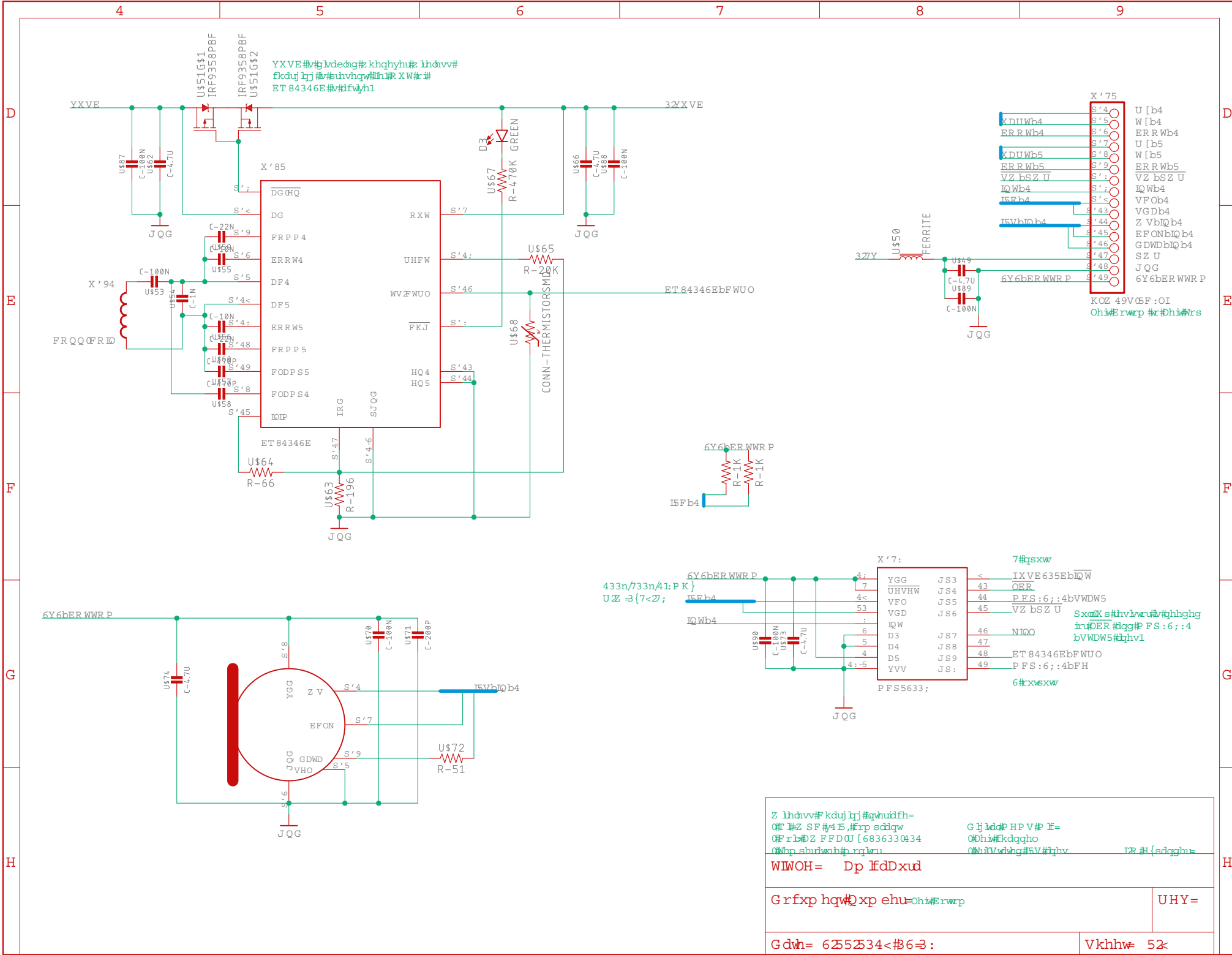

YXVE #/b1vdeog# khqhyu# lh0vv#
 fkdij lqj #/b1vhqg#lh1R XW#:#
 ET 84346E #/b1fwh1

X'75
 S'4 U [b4
 S'5 W [b4
 S'6 ERRWb4
 S'7 U [b5
 S'8 W [b5
 S'9 ERRWb5
 S'1 VZ bSZ U
 S'2 IQWb4
 S'3 VFOb4
 S'43 VGDb4
 S'44 Z VbIQb4
 S'45 EFONbIQb4
 S'46 GDWDbIQb4
 S'47 SZ U
 S'48 JQG
 S'49 6Y6bERWWR P
 KOZ 49Vb5F :OI
 Oh#Erwrp #z#Dhi#hrs

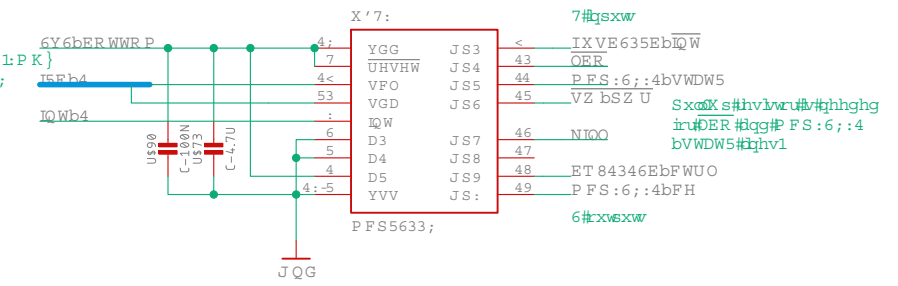
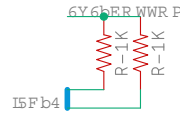

Z lh0vv# fkdij lqj #/b1vdeog# khqhyu# lh0vv#	G ljldeP HP V#P f#
Oh#Z SF #/45, #erp sdiqg	Oh#kdkqgho
Oh#rlbDZ FFDU [6836330434	Oh#Wdwhg#5V #tqhv
Oh#pshurwkh#p rqlw1	IR # (sdqghu=
WlwoH= Dp IfdDxud	
G rfxp hqg# xp ehU=Oh#Erwrp	UHY=
G dwh= 6252534 <#6-3<##031k8## =X vhw G rfxp hqg HDJ OH surhfw Dp IfdDxud Dp IfdDxudlvfk#Vkhhw#52,	Vkhhw= 52<

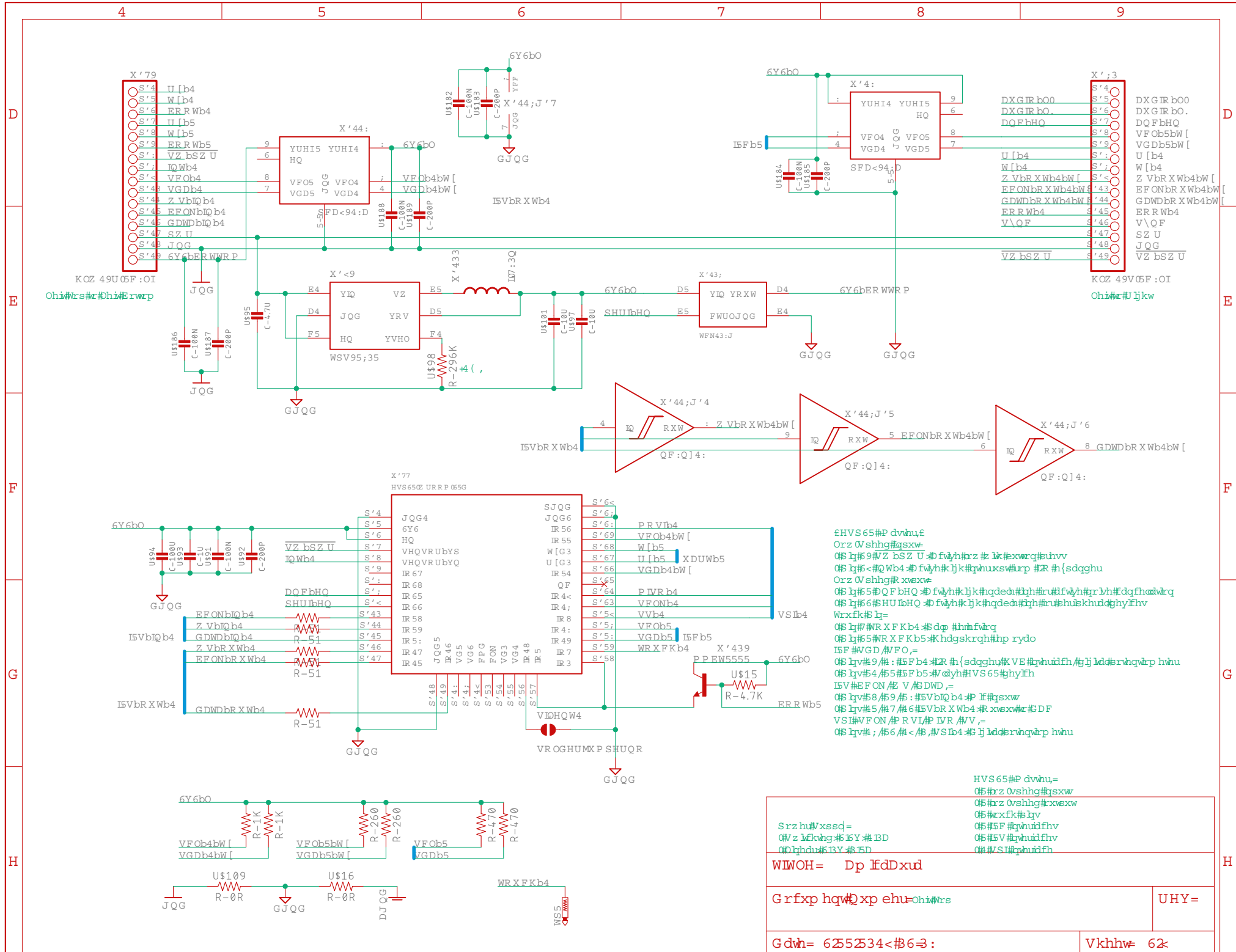

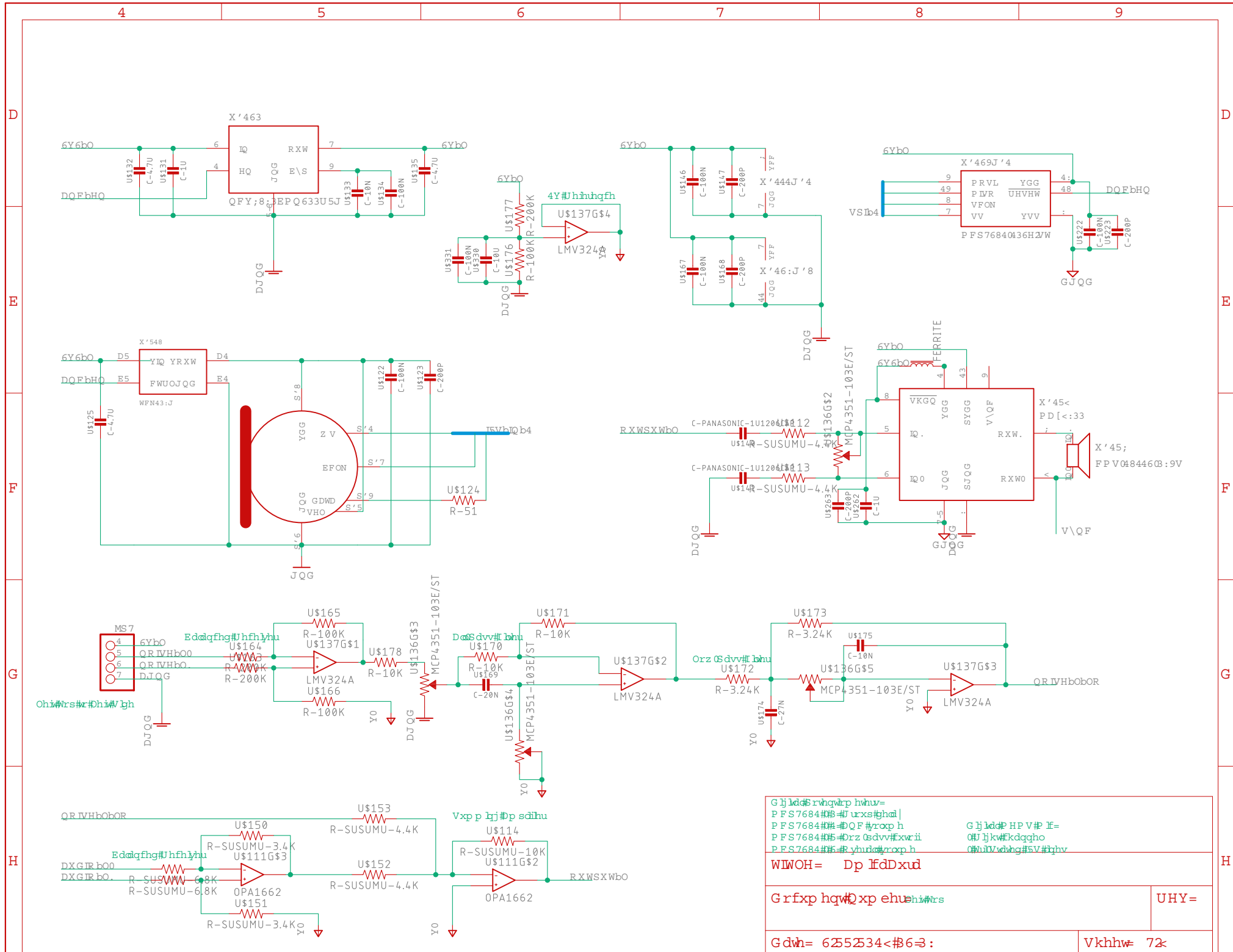

Gijld6rvhgwpr hnw=
PFS7684#B=# uxshgal | Gijld6P VV#P F=
PFS7684#B=#DQF#zoop h OJ jkw#kdgqho
PFS7684#B=#Orz Qsdv#Exwii O#uV#wbng#5V#qhv
PFS7684#B=# yhud#zoop h

WlWOH= Dp lfdDxd

G rfxp hqw xp ehv hnwrs UHY=

G dhw= 625234<#6-3: Vkhhw= 72<

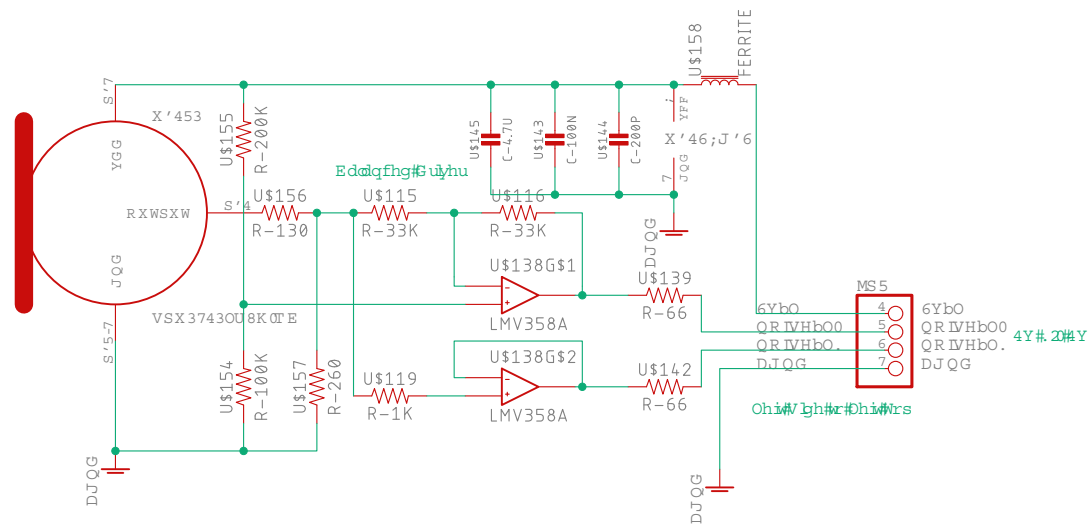

WlWOH= Dp lfdDxud	
G rfxp hqwxp ehushiwgh	UHY=
G dwn= 6255234<#6-3<##@31k8##[-X vhw G rfxp hqwx HDJ OH sunfw Dp lfdDxud Dp lfdDxud lfk#V khhw#82<	Vkhhw= 82<

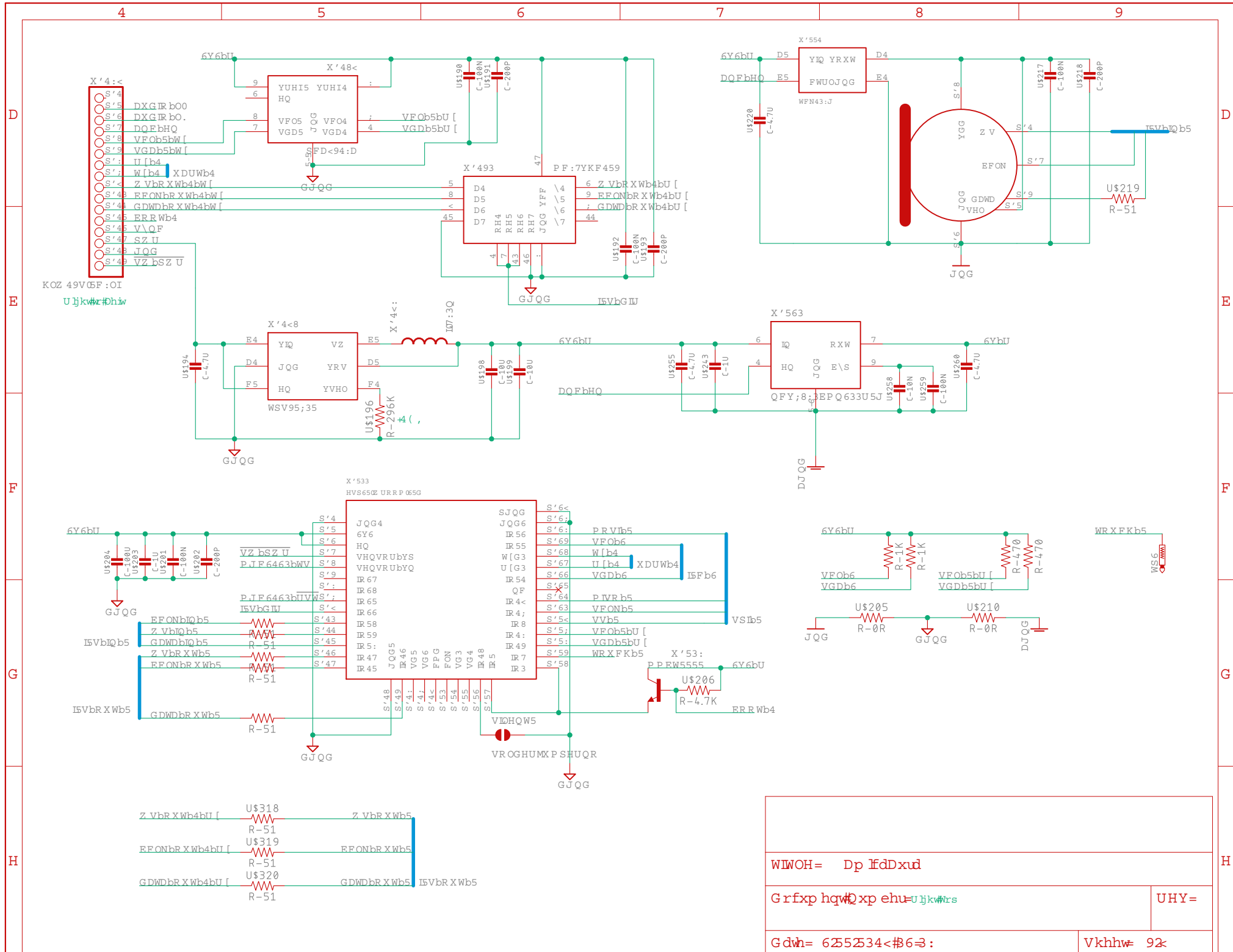

625234<#63<##@31k8##=-XvhwGrfxp hqw HDJ OH sumfw Dp Ifd#Dxud Dp IfdDxud\fk#Vkhhw#2< ,

WlWOH= Dp IfdDxud	
Grfxp hqw xp eh=Uljkwrs	UHY=
Gdhw= 625234<#63<:	Vkhhw= 92<

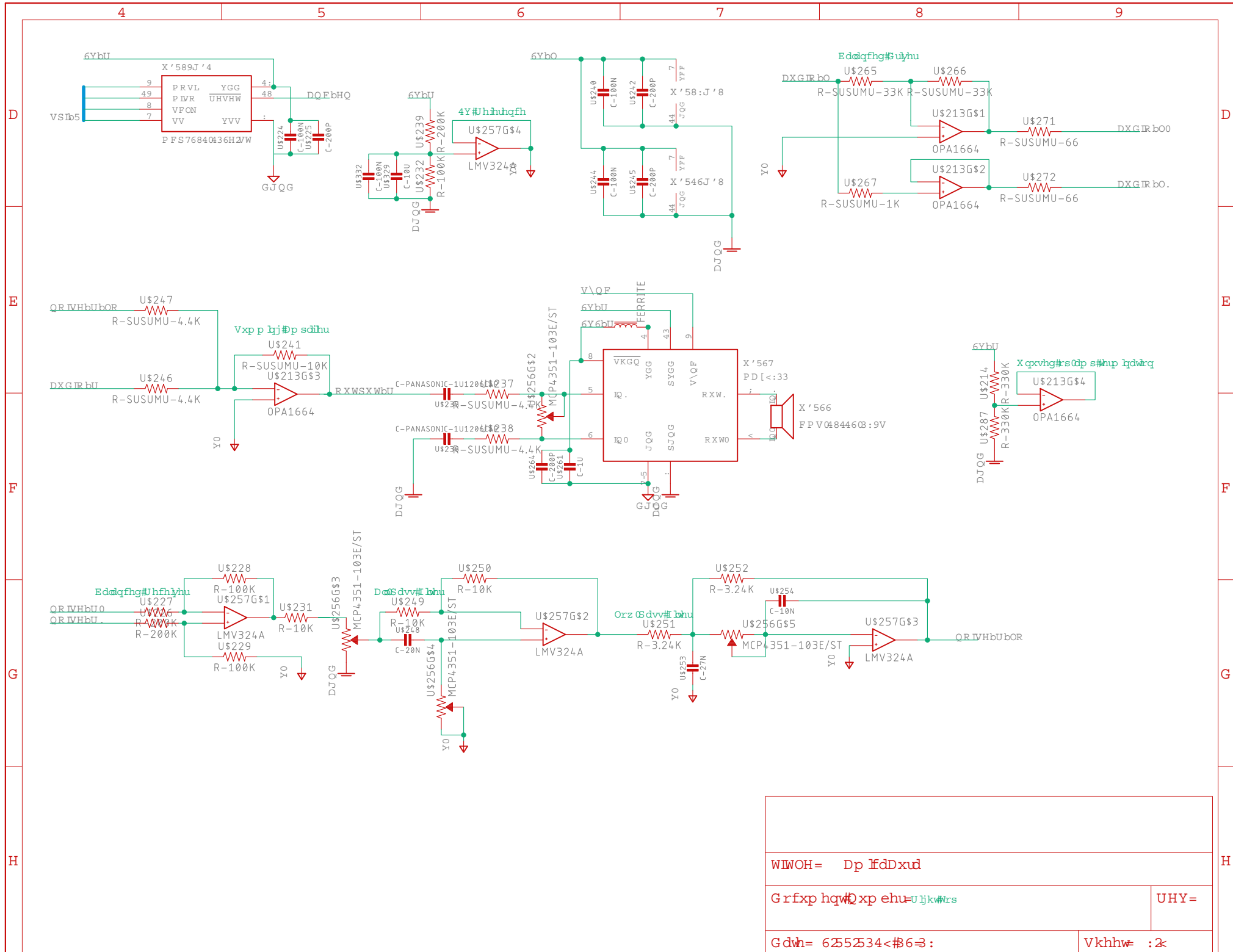

625234<#63<##031k8##[-X vhw G rfxp hq w HDJ OH sunfw Dp lfdDxud Dp lfdDxud\fk#Vkhhw# 2,

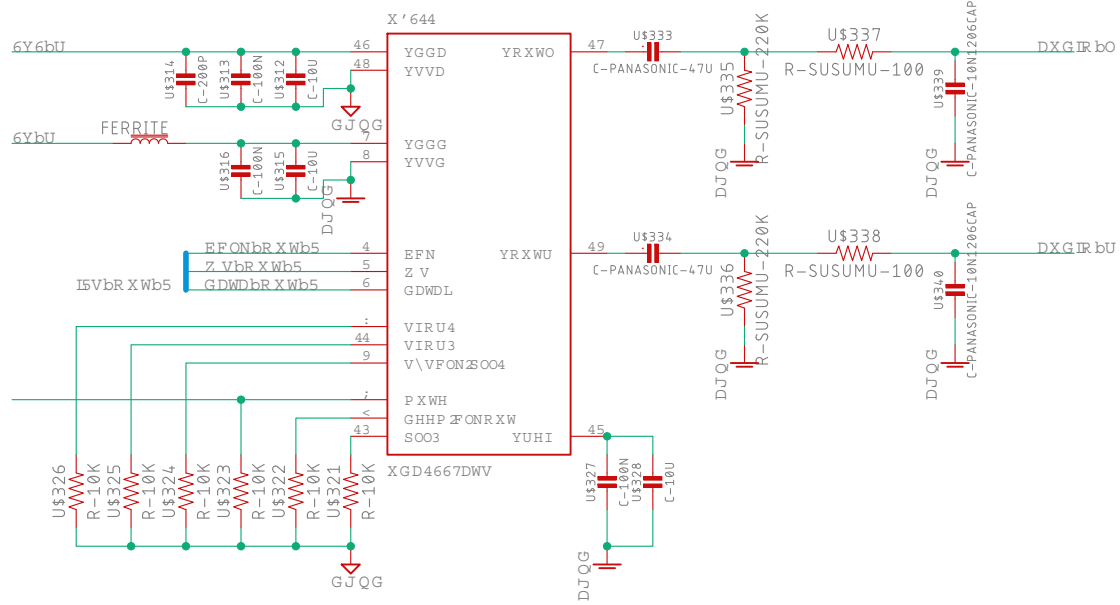

WIWOH= Dp lfdDxud	
G r f x p h q w D x p e h u = U l j k w r s	UHY=
G d w h = 6 2 5 2 3 4 < # 6 3 :	V k h h w = ; 2

D

E

F

G

H

D

E

F

G

H

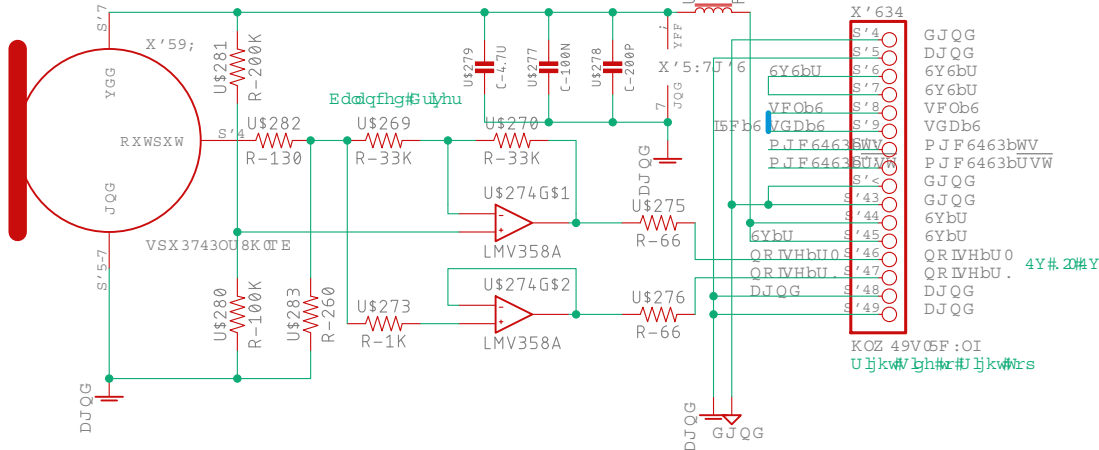
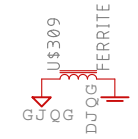
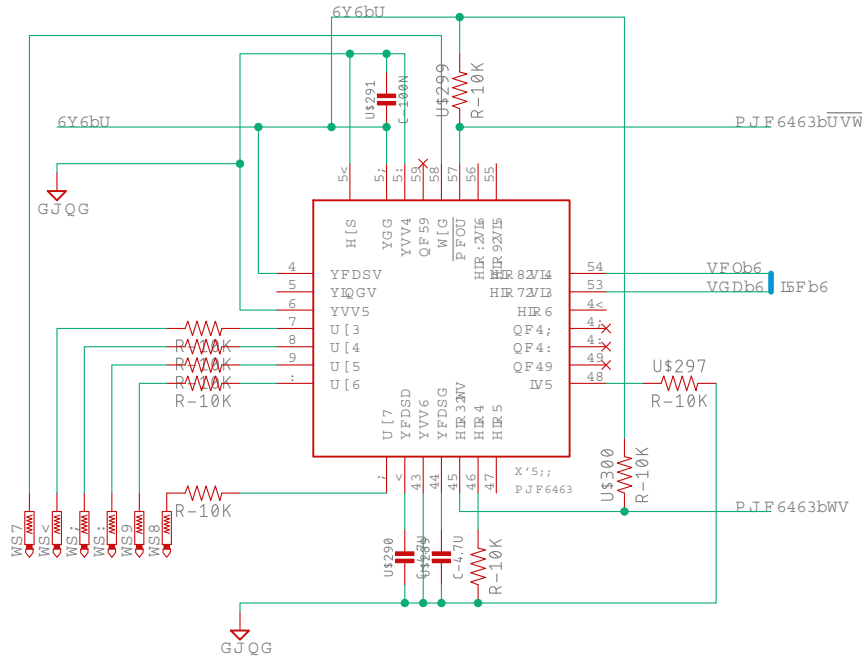

WIWOH= Dp IfdDxud	
G r f x p h q w D x p e h u U j k w l g h	UHY=
G d w h = 6 2 5 2 3 4 < # B 6 3 :	V k h h w < 2